



PROJECT MUSE®

---

## The Limit of the Visual World

Fernando R. Casas

Leonardo, Volume 26, Number 2, April 1993, pp. 159-164 (Article)

Published by The MIT Press



➔ For additional information about this article  
<https://muse.jhu.edu/article/606955/summary>

# The Limit of the Visual World

Fernando R. Casas

**H**uman beings cannot see their own heads. This is obvious. What is not obvious is whether this limitation is due to anatomical features (frontality, binocularity, etc.) or due to an optical feature inherent in the nature of visual representation itself, affecting any observer including the conceivably perfect one. Can such an ideal observer see himself? (I use the male gender in referring to this conceptual being for the sake of linguistic simplicity.)

Far from obvious, the answer to this question is that the ideal observer will see himself in his visual world in one sense of the term “see” but not in another. He will see himself in the world that he perceives in the sense that he can see his own location in relation to the other objects he sees. But he will not be able to see himself in the sense that, at that location (his head), no object appears—rather what he sees is a blind spot, a void. This dual aspect of the fact that the ideal observer can see himself as a void in his visual field reveals that vision encompasses two mapping systems: a *system of visual spatial reference* and a *system of visual appearances*. The first system creates a complete map of spatial localities, the second an incomplete map of appearances. Finally, the fact that a visual observer can see himself in the world, but sees himself as the limit of the world of objects, is a fact pregnant with philosophical implications, some of which I will briefly mention at the end of this paper.

## THE MOMENTARY VISUAL FIELD AND THE SPHERICAL VISUAL FIELD

The concept of the (human) visual field in the psychology of vision is that of an expanse given by a momentary visual stimulation of the retina—the “proximal stimulus.” It is commonly agreed that its range and shape are that of an oval expanse covering roughly 150° of visual angle vertically and 180° horizontally. The human visual field is thus thought to be made of colored patches, textures and surfaces divided by contours that stimulate the human eye, momentarily creating an overall field of the shape and range described above.

Consider now a most fundamental fact about vision: The visual world, the field that is available for visual inspection, surrounds an observer completely. This field is therefore a *spherical field*. We can easily confirm that this is the case by turning our gaze in any direction we wish (up, down, right, left, etc.) and finding in every case the visual world. But the visual apparatus of human beings, the result of our biological evolution, allows us to see only a portion of this surrounding visual world at any given time. Our limited momentary visual stimulation, the product of binocular frontality, covers only a portion of this surrounding visual world. The aggregate of all of these momentary visual fields forms a spherical surface, and this

spherical surface is indeed available to human beings, not all at once but in segments [1]. In this sense, human beings have a spherical visual field [2]. Figure 1 shows an observer surrounded by the visual world and its corresponding spherical visual field. It also shows the relationship between the spherical visual field and the momentary visual field.

Realizing the limitation of the momentary human visual field, one may be inclined to conclude that the reason human beings cannot see their own heads is precisely because their visual fields provide them with only a partial view of all that there is to see at a given time. If human beings were endowed with the capacity to see in all directions at once, then one might be inclined to believe they could see themselves. Do we fail to see our heads simply because we cannot see in all directions at once? Can an ideal observer—one who can see all around at once—see himself?

## A BLIND SPOT MANIFESTS ITSELF AS A BLANK SPOT

In order to answer the above question we need to inspect all parts of the spherical visual field simultaneously. This can be done with the aid of *spherical perspective* and *flat-sphere perspective*. Spherical perspective allows us to create a picture of the complete spherical visual world [3]. With flat-sphere perspective we can transform this spherical image into a flat picture.

Figure 2 shows a painting created with the aid of flat-sphere perspective. The observer in that painting sits on the ground and can see all around. His spherical visual field, conceived of as elastic (like a bubble), was pierced at a point on top of the spherical field and then flattened out, stretched so much that the point became the periphery of the whole picture. This picture is an accurate representation in the sense that the neighborhood relations of every identifiable item in the visual world have been maintained in the picture (e.g. a white house appears to the left of a building, below a

### ABSTRACT

**H**uman beings cannot see their own heads. But could an ideal observer—with the ability to see all around at once—see himself directly? The author postulates that this ideal observer could see himself as a localized and irremovable blind spot. Paradoxically, the ideal observer sees himself as the ultimate limit of his visual world.

Fernando R. Casas (artist, philosopher), P.O. Box 753, Magnolia, TX 77355, U.S.A.

Received 19 December 1990.

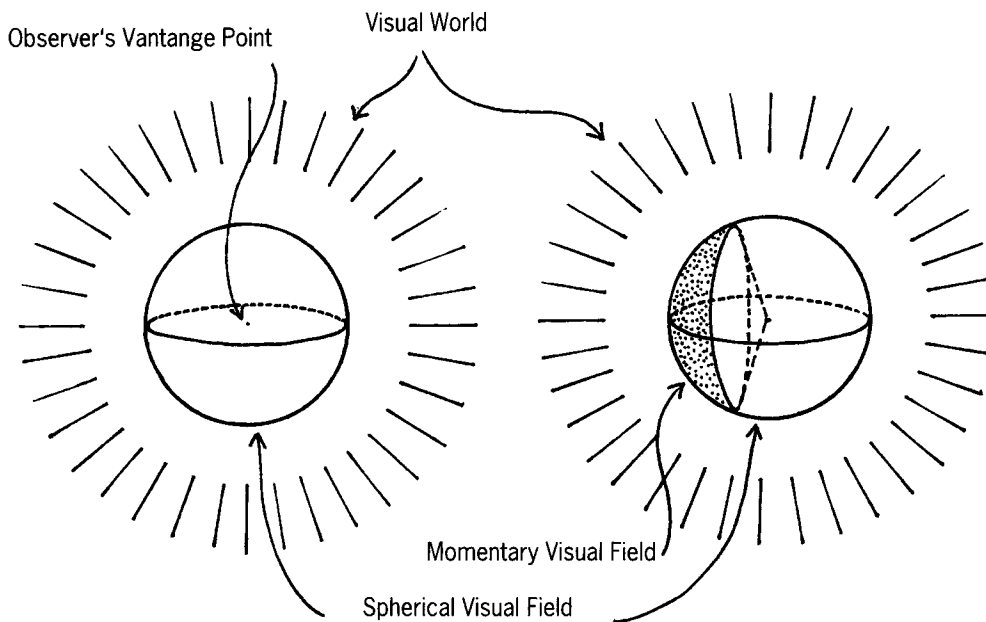

Fig. 1. (left) An observer is represented, surrounded by the visual world and its corresponding spherical field, which humans have access to only in portions (called *momentary visual fields*). (right) The limitation of a momentary visual field is represented by the shaded area of the sphere.

cloud, to the right of a tree). Every visual item in such a picture will have a unique set of neighbors, and it will be an accurate depiction of the visual world only if such neighborhood relations also hold true in the visual world.

The observer in that painting does not have a head. Notice, moreover, that in the place of the head there is a blank spot. Is this accurate? It is obvious that the observer cannot see his own head, but why leave a blank in place of the head? Would it not have been more accurate to suture this void, eliminating it from the picture? The answer is no.

Under the assumption that we want to produce an accurate picture, this blank spot cannot be eliminated. Its elimination would contradict the neighborhood relations that hold true in the visual world.

Consider the neighborhood relations of the right shoulder of the observer in the picture: on its right side we find some grass, on top of it the arm; below it, more of the ground and grass. But what is the neighbor of this right shoulder on its left side? It surely is not the other shoulder. We do not see our two shoulders next to each other in our

visual field. They are separated and, disquietingly, we do not see what keeps them apart. Clearly, then, between the two shoulders there is a blind spot: a place, or expanse, of the spherical visual field where we see nothing. It follows, then, that we cannot eliminate this blank area in the picture because if we did so we would be depicting the two shoulders as immediate neighbors of each other, and this is not how things are in the visual world; such a drawing would contradict our visual information.

One may be inclined at this point to believe that we have found the answer to our question: the presence of this blind spot in the complete sphere of vision proves that even an ideal observer cannot see himself. One is inclined to believe, then, that this blind spot stands for the space occupied by the head that cannot see itself. But this is simply not so. What produces this blind spot is not the fact that the human eye, or any other optical apparatus, cannot see itself directly. Rather it is the relatively trivial fact that our heads are connected to our bodies through necks.

Compare the observer of Fig. 2 with an optically equivalent object: a spherical photographic camera—a presently nonexistent, yet conceivable, object. This camera would contain spherical photosensitive film surrounded by multiple apertures that allow a projection of the complete surrounding visual space. If we imagine this camera floating in space (Fig. 3a), then we can see that it could take a picture of the surrounding world without any blank spots. We do not need

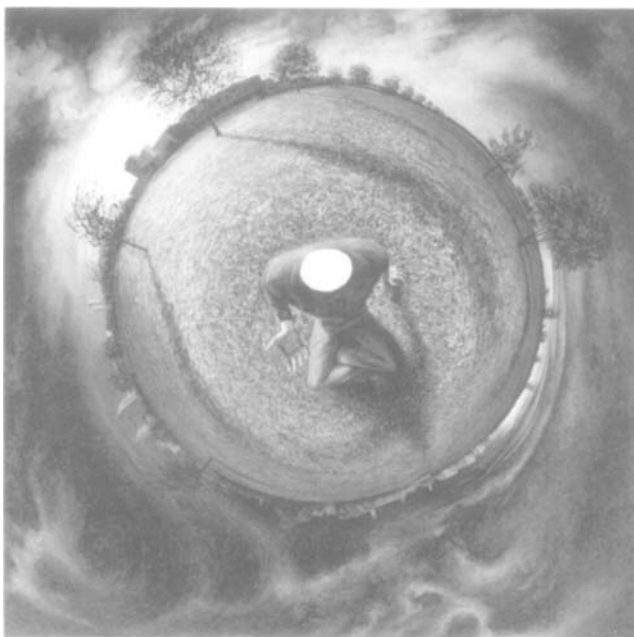
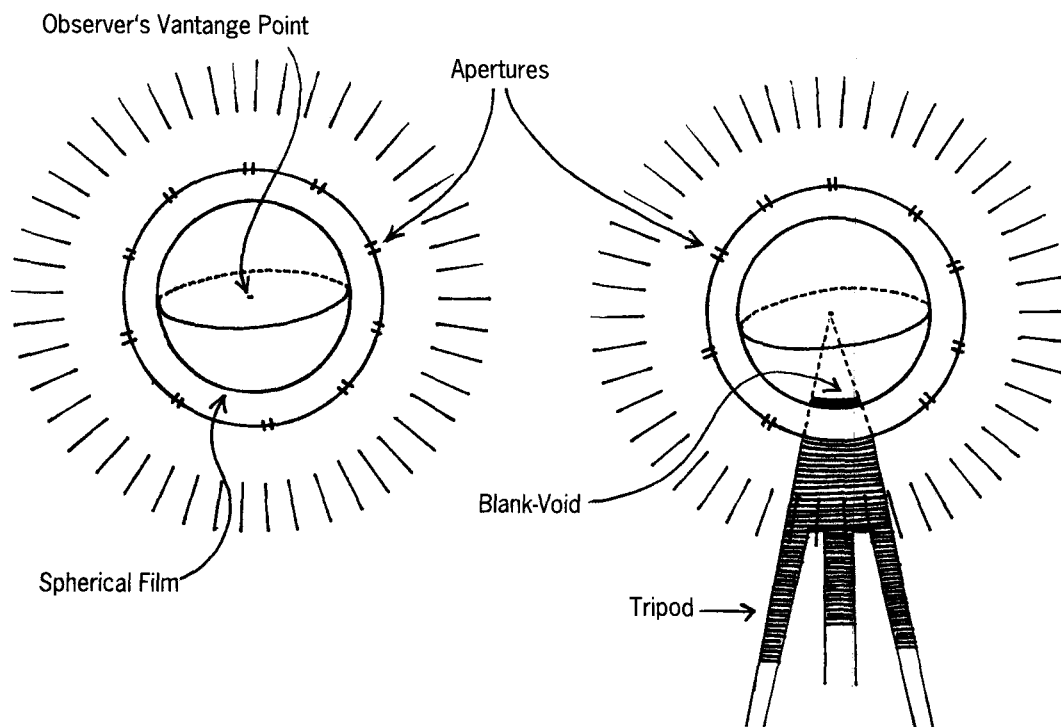

Fig. 2. Fernando Casas, *Approaching Storm*, oil on canvas, 78 × 78 in, 1983. This flat-sphere image is an accurate representation of this observer's perception. An accurate representation must include a blank space between the two shoulders because they are not neighbors of each other in the visual world—something that the observer cannot see separates them.

Fig. 3. (left) A nonexistent, yet conceivable, spherical camera floating in space. This camera has a spherical photosensitive film surrounded by apertures that allow the projection of an image of the entire surrounding visual world onto the film. (right) When the spherical camera is made to stand on a tripod, the tripod will “stand in the way” of the camera’s complete recording of the surrounding visual world.



to await the development of this camera in order to know that this is true. The image that it would create would be optically identical to the image that a floating mirror ball (or a bubble) creates on its surface. The spherical image that appears on the surface of a mirror ball looks perfectly complete: there are no blank spots on it. Consequently, the blank spot of Fig. 2 is not a necessary feature of a spherical visual representation in general. It is a human feature that ensues from the peculiar human anatomical makeup.

That this is the case can be seen clearly when we imagine the same spherical camera (or alternatively, the mirror ball) not floating in space but resting on a set of legs: a tripod (Fig. 3b). Because the tripod stands between the film and some portion of the visual world, it inevitably blocks from view some portion of the visual world. Consequently, the tripod produces a blank area on any spherical picture of the surrounding space. Similarly, at any given moment, our necks, connected to our bodies, block our view of a portion of the visual world.

The reason that the blank spot could not be eliminated in Fig. 2 was that that image was an accurate representation of the sphere of vision of a *human observer*. We were still operating within an anthropocentric situation. Again we must address our original question: can an ideal observer see himself—assuming an ide-

al observer is one that can see in all directions at once, unimpeded by neck or tripod, an observer with a visual-image capacity equivalent to that 360° image which appears on a floating bubble?

### AN OPTICALLY NECESSARY BLIND SPOT: A SPHERICAL VOID

A spherical mirror such as a floating bubble exists as one among many objects in a three-dimensional (3D) space. When we examine the image on its surface we can, in principle, find in it all objects of that 3D world except the bubble itself. The image on its surface is therefore incomplete. In order to be a complete image of the totality of that space the bubble should include itself in its image. This is so because the bubble belongs to the same space that it reflects—as we can witness when we look at it from outside. But the bubble does not and cannot reflect itself. How can the 3D space that appears on a mirror ball look so perfectly complete and coherent when in fact it is not? This is a puzzling phenomenon. Somehow a spherical mirror hides its own incompleteness; the image it creates does not make it obvious that there is some portion of that space that is missing. Yet, appearances aside, the incompleteness exists. There must be a hidden blind spot on that spherical image.

The blind spot on the spherical image is not readily apparent precisely because it is a blind spot. The familiar blind spot of our monocular vision [4] is not readily apparent—we must undergo a certain procedure in order to display its existence. Similarly, we need to envision a certain procedure in order to make this ultimate visual blind spot apparent. One becomes aware of the presence of the monocular blind spot when one moves an object towards its location. One sees it disappear as it enters the location of the blind spot and reappears on the other side of the blind spot, having traversed its length invisibly. We will investigate a spherical mirror in a similar manner and discover that it discloses a similar blind spot.

Let us imagine a bubble floating in the middle of a room. Instead of imagining a moving object traversing the bubble, let us imagine a ladder that extends from one side of the room to the other and which also traverses the inside of the bubble (Fig. 4). The two sections of the ladder outside the bubble project an image onto the surface of the bubble. But just as a moving object disappears (for the human eye) when it traverses the monocular blind spot, the portion of the ladder inside the bubble disappears for the ideal observer because it cannot project an image onto the bubble’s surface. Consequently, the spherical image on the bubble’s surface will contain an

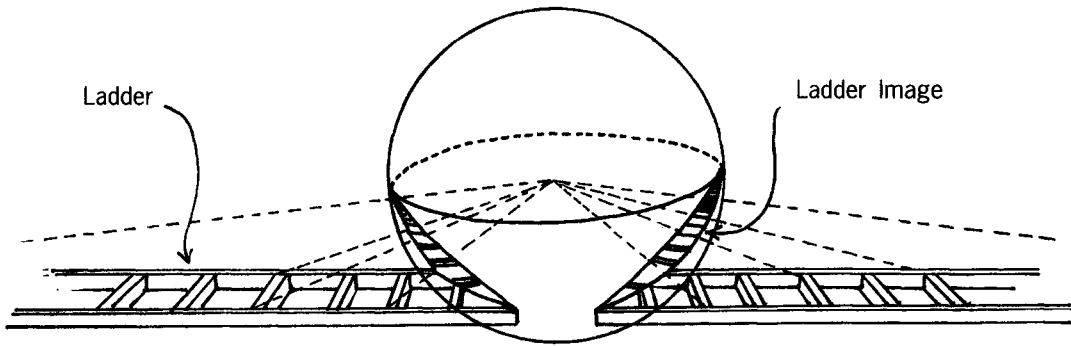

Fig. 4. A ladder traverses a spherical visual field. Only those portions of the ladder that lie outside the sphere—not the portion inside the sphere—can project an image onto the surface of the sphere.

image of the ladder with a portion of the ladder missing. This missing portion, or rather, the portion of space where the ladder disappears, is clearly displayed as a blind spot in the flattened spherical image of the bubble in Fig. 5.

This blind spot is a location that has no appearance (color, texture, etc.) whatsoever. It is the portion of space between the two appearing sections of the ladder. This portion of space is a portion of the 3D world of the spheri-

cal image, not of the two-dimensional (2D) visual field. It is a 3D void where nothing appears (e.g. it has no color, no light value). Yet this void belongs to visual space in the sense that it can be displayed visually (as in Fig. 5) and in the sense that it is a definite location in the visual world.

Fig. 5. The spherical visual field of Fig. 4 has been flattened. One can see that the ladder disappears at some locality of the 3D space of the image. This locality is a 3D void that is part of the 3D world of the spherical image. This void is an optically necessary blind spot.

The blank spot portrayed in Fig. 2 was a 2D blank area of the spherical surface. The void that we have just disclosed, on the other hand, is a 3D void that belongs to the illusionary 3D space of the spherical image. This difference explains why, in Fig. 5, we cannot see the portion of the ladder that is inside the spherical void, but we can see the floor under the ladder or “beyond the void,” so to speak. The reason the floor is seen—but this portion of the ladder is not—is because the floor is outside the bubble; the section of the ladder that is inside the bubble cannot be “seen” by the bubble.

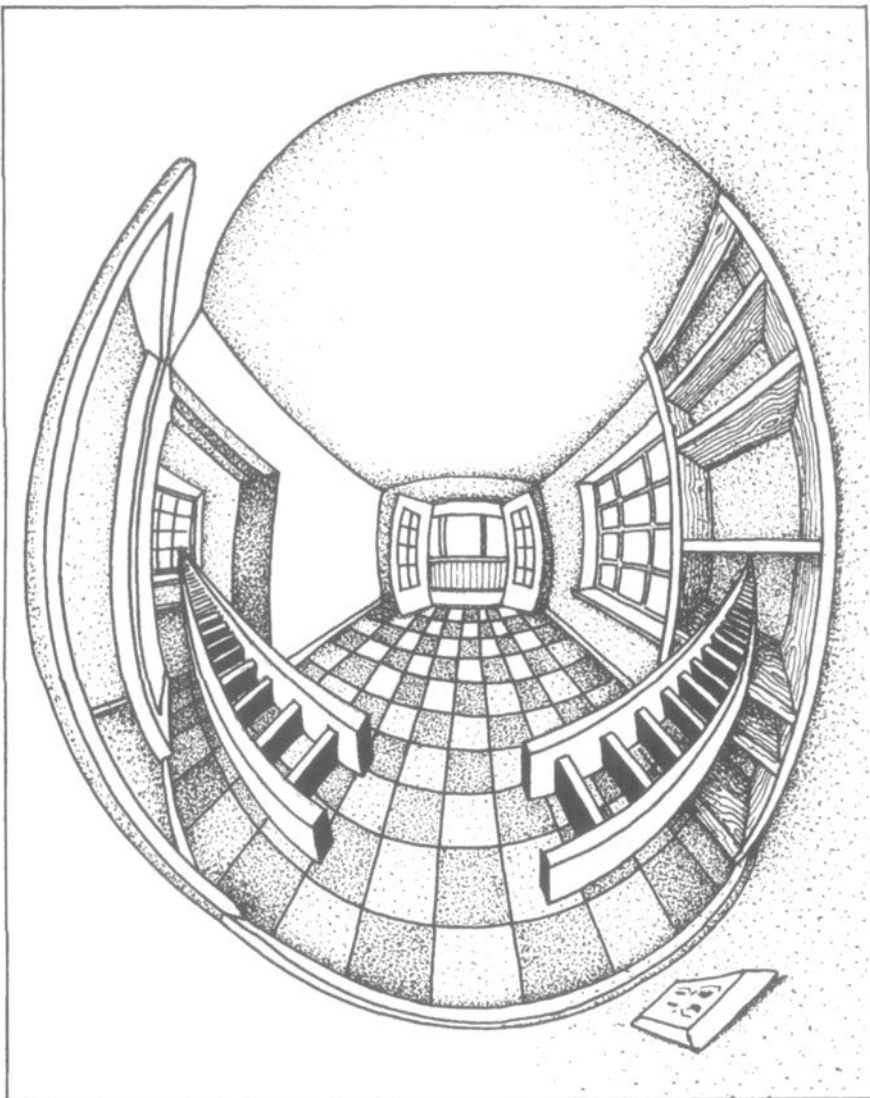

Consider once again the bubble in the middle of a room. Instead of a ladder, imagine a sheet of paper somewhat larger than the bubble moving toward the bubble and eventually traversing it. As the paper approaches the sphere, the spherical observer will see the whole sheet of paper. But the moment that a portion of the sheet of paper begins to traverse the inside of the bubble (Fig. 6), the spherical observer will be able to notice a portion of the sheet of paper disappearing; at first a small circular portion will disappear, then larger and larger circular portions will disappear until the portion of paper that disappears is equivalent to the diameter of the bubble. The process reverses when the sheet moves through the other hemisphere of the bubble. The sheet of paper will look once again complete the instant that there is no longer any portion of it inside the bubble. In this case, the blind spot manifests itself much more fully than it

did with a single ladder. Here the ideal observer can visually witness a succession of void circular surfaces. The collection of all of these void circular surfaces define quite precisely a spherical void in the 3D space of the spherical image. This spherical space corresponds exactly to the spherical space that the bubble itself occupies; the bubble manifests itself on its image as a void.

This spherical blind spot is a necessary feature of all optical spherical representations of visual space. It is so because the only way of eliminating it is by reducing the size of the reflecting sphere to zero magnitude. But a sphere that has no magnitude has no surface on which to create the visual representation either. Consequently, as long as there is a surface with some magnitude, there will also be some interior space that cannot be reflected.

### VISION: A DUAL MAPPING SYSTEM

When we examine a spherical visual field, we find that all objects in it have an *appearance*—that is, they have color, texture and light value. But unlike everything else in the visual field, the spherical void, which belongs to the visual field, lacks any *appearance*. Although the void has a definite location in the visual world, it does not present itself as an object, for, unlike all objects, it does not have color, texture or light value. It is merely some 3D volume in which nothing appears. The spherical void in the visual field, then, shows us that the ideal observer is present in his visual world as a location but is not and cannot be present as an object having an appearance.

This shows that within vision, understood as a mapping system of optical representations, two different mapping systems are in operation: one of locations, the other of appearances. Visual representation is a *complete system of spatial localization* because nothing fails to obtain a locality in the ideal visual field—including the image itself. But visual representation is an *incomplete system of visual appearances* because even the ideal visual image will fail to give an appearance to the location occupied by the image itself. The purely spatial visual representation of locations and the representation of appearances are not equivalent. Subtracting the second from the first yields the inevitable blind spot.

Can an ideal observer see himself? The answer is yes and no.

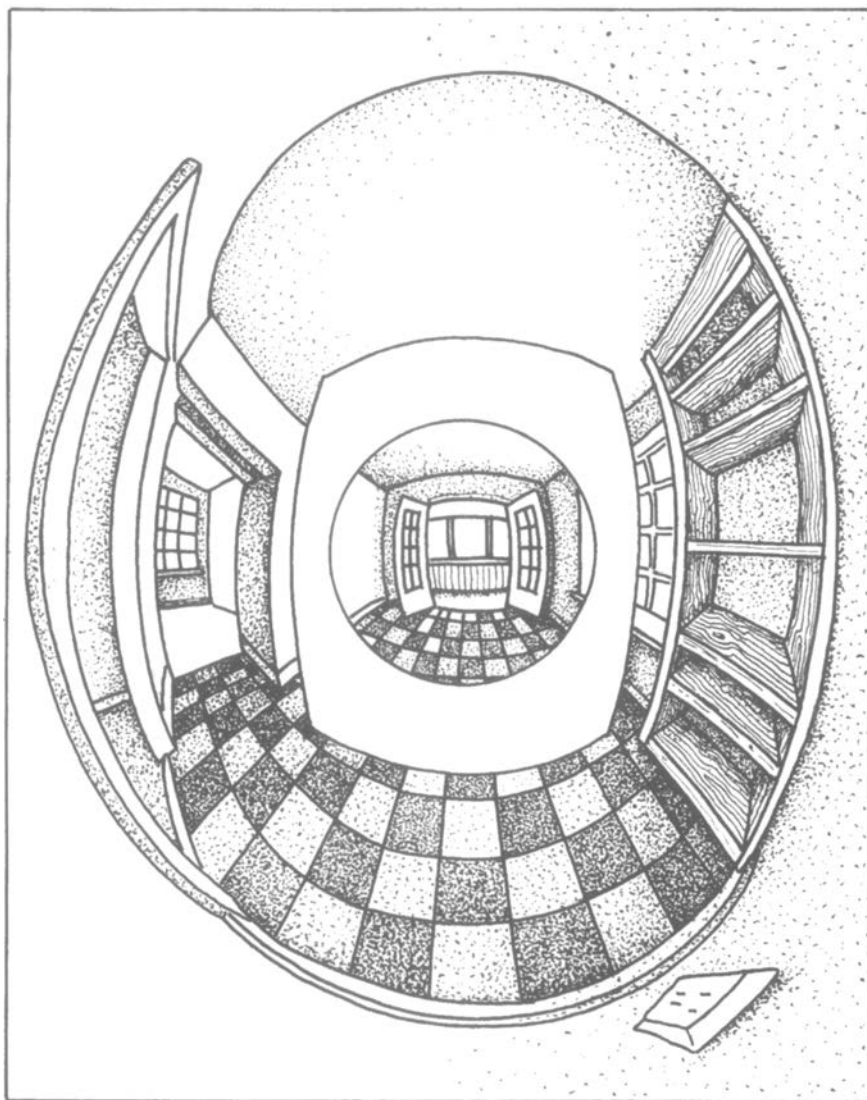

Fig. 6. A sheet of paper traverses the spherical visual field of an ideal observer. When the sheet of paper is outside the sphere, it projects a complete image of its surface onto the spherical field. As portions of the paper enter the sphere, these portions disappear from the spherical image. These portions are circular sections that, starting with a minuscule point, increase in size as the sheet moves into the sphere.

Remarkably, the answer is yes in the sense that the observer can see himself as a localized void in his visual world. The answer is no in the sense that his presence in the visual world is not that of an object having an appearance, but rather it is the presence of a void. The description of the visual experience that grasps both these features at once is the experience of a boundary: where the world of objects and appearances ends and a mysterious void presence begins.

Since what lies inside the void of a spherical visual representation is the reflecting sphere or the observer himself, we can justly say that *vision manifests itself visually in its own field*—that is, that vision is a self-referential system. But it is self-referential in a paradoxical way: it presents itself as *the limit* of the

world of visual objects, as the location where the world of visual appearances comes to a stop.

Although the ideal observer cannot see himself as a visual object, he can nevertheless visually experience himself as the limit of his visual world. Clearly, one cannot see anything on the “other side” of the world of objects. However, one can visually experience the presence of that “other side” (or, more accurately, the presence of “this side,” since this is the location of the self). The ideal observer then will be able to see the visual mark that “this side” (he) produces in the fabric of his own visual world of appearances. An ideal visual observer, then, can directly see the boundaries of his visual world of appearances and, in so doing, can

also directly see himself—not as an object among other objects but as a necessary limit of his world of appearances: as a “metaphysical subject.”

This remarkable feature of vision gives support to the visual and ontological claims made by Wittgenstein in *Tractatus Logico Philosophicus*, in which he characterizes the metaphysical self as the limit of the world [5]. This finding also directly contradicts D. Hume’s claim that one cannot find oneself in experience [6]. One certainly does so, not as an object, but rather as a *limit of the world*.

### Acknowledgments

I am greatly indebted to artist Steve Adams for his help in the preparation of this text. I am also grateful to philosophers Ileana Marcoulesco and Bruce Leutwyler of the International Circle for Research in Philosophy for their valuable critical observations.

### References and Notes

1. A spherical surface is, in principle, able to capture all of the surrounding visual world as far as vision can go or light rays can travel. The fact that an object, such as a wall, may on occasion obstruct the view of other objects that stand “behind” it (relative to the observer) does not alter the fact that, on a spherical visual field, light rays can, in principle, converge, bringing visual information from every corner of the visual world. The only portion of the world—in a sense—that is excluded from creating an image on a given spherical reflecting surface is that portion of space that in general relativity is called “elsewhere.” From “elsewhere” it is physically impossible, given the finite speed of light, for a pulse of light to reach a reflecting sphere that lies outside the four-dimensional cone of light created by the pulse. See, for example, P.C. Davies, *The Edge of Infinity* (New York: Simon and Schuster, 1981).
2. The concept of the visual field as a spherical surface is part of the operating model of vision in the field of curvilinear perspective, as practiced and discussed by artists and/or authors A. Flocon, R. Hansen, F. Casas, J. Lima, D. Termes, etc. The notion of the momentary visual field has had the unfortunate role of de-emphasising the fact that the visual world surrounds us. In order to understand the idea of the spherical visual world and to become conscious of its surrounding reality, it is necessary to overcome the narrow and anthropocentric tendency to think of the visual world simply as that frontal expanse that is present to the *human eye* in partial

*momentary views* (what philosopher M.D. Levin calls tunnel vision). Just as the binocular visual field is a mental construct, so too is the spherical visual field. One can become more conscious of the spherical field by realizing that in every momentary visual field the total sphere of vision is also present. This is so for several reasons: (1) The momentary visual field is never a well-defined, static field. On the contrary, as psychologists have found out, it is a constantly fluctuating field with ill-defined borders. These fluctuations are displacements within the spherical field. The total sphere of vision is present as the horizon of possibilities (speaking in phenomenological terminology) of future momentary visual fields. (2) The momentary visual fields are not given to us as disconnected portions of visual space. Rather we connect them and organize them into a global spatial arrangement. This is evident from the fact that we often infer the spatial relations between two objects (e.g. next to, in front of) even when these objects appear in different momentary visual fields. Hence we operate by implicitly organizing the different panoramas into a coherent whole. But in spite of this implicit global organization and in spite of planetariums and fish-eye photography, human beings today (lay people and specialists alike) seem to lack an explicit awareness of this visual spatial totalization.

3. F.R. Casas, “Flat-Sphere Perspective,” *Leonardo* 16, No. 1, 1–9 (1983); and F.R. Casas, “Polar Perspective: A Graphical System for Creating Two-Dimensional Images Representing a World of Four Dimensions,” *Leonardo* 17, No. 3, 188–194 (1984).
4. The monocular blind spot is a location in a monocular visual field where the observer sees nothing. This is due to the fact that there is an area in the retina that has no receptors because at that location the nerve connections forming the optic nerve exit the eye. See, for example, R. Norman Haber and M. Hershenson, *The Psychology of Visual Perception* (New York: Holt, Rinehart and Winston, 1980).
5. Ludwig Wittgenstein, *Tractatus Logico Philosophicus* (New York: Routledge and Kegan Paul, 1963). See Propositions 5.632, 5.633 and 5.6331.
6. David Hume, *An Inquiry Concerning Human Understanding* (Chicago, IL: Gateway Editions, 1956).

### Bibliography

- Adams, Kenneth R., “Tetraconic Perspective for a Complete Sphere of Vision,” *Leonardo* 9, No. 4, 289–291 (1984).
- Arnheim, Rudolf, *Art and Visual Perception* (Berkeley and Los Angeles: Univ. of California Press, 1974).
- Davies, P.C.W., *Space and Time in the Modern Universe* (Cambridge: Cambridge Univ. Press, 1978).

Flocon, A. and A. Barre, *Curvilinear Perspective: From Visual Space to Constructed Image*, with an introduction by Robert Hansen (Berkeley: Univ. of California Press, 1987).

Gibson, J.J., *The Perception of the Visual World* (Boston: Houghton Mifflin, 1950).

Gibson, J.J., “Visually Controlled Locomotion and Visual Orientation in Animals,” *British Journal of Psychology* 49, No. 3, 182–194 (1958).

Gibson, J.J., *The Senses Considered as Perceptual Systems* (Boston: Houghton Mifflin, 1966).

Gibson, J.J., and F.N. Dibble, “Exploratory Experiments on the Stimulus Conditions for the Perception of Visual Surface,” *Journal of Experimental Psychology* 43, No. 6, 414–419 (1952).

Gombrich, E.H., *Art and Illusion: A Study in the Psychology of Pictorial Representation* (Princeton: Princeton Univ. Press, 1972).

Goodman, Nelson, *Languages of Art* (Cambridge: Hackett, 1976).

Hochberg, J.E., “The Psychophysics of Pictorial Perception,” *Audiovisual Communication Review* 10, No. 4, 22–54 (1962).

Hochberg, J.E., “In the Mind’s Eye,” in D.I. Mostofsky, ed., *Attention: Contemporary Theory and Analysis* (New York: Appleton-Century-Crofts, 1970).

Hochberg, J.E., “Perception: II. Space and Movement,” in J.A. Kling and L.A. Riggs, eds., *Woodworth and Schlosberg’s Experimental Psychology* (New York: Holt, Rinehart and Winston, 1971).

Hochberg, J.E., “Art and Perception,” in E.C. Carterette and H. Friedman, *Handbook of Perception* (New York: Academic Press, 1978).

Hochberg, J.E., “Perception of Successive Views,” *Science* (1980).

Levin, David Michael, *The Opening of Vision* (New York: Routledge, 1988).

Merleau-Ponty, Maurice, *The Primacy of Perception* (Chicago: Northwestern Univ. Press, 1964).

Moose, Michael, “Guidelines for Constructing a Fisheye Perspective,” *Leonardo*, 19, No. 1, 61–64 (1986).

Paris, J., *L’espace et le regard* (Paris: Editions du Seuil, 1965).

Rucker, Rudolf v. B., *Geometry, Relativity and the Fourth Dimension* (New York: Dover, 1977).

White, John, *The Birth and Rebirth of Pictorial Space* (Cambridge: Belknap Press of Harvard Univ. Press, 1987).

Wittgenstein, Ludwig, *Tractatus Logico Philosophicus* (New York: Routledge & Kegan Paul, 1963).

Wittgenstein, Ludwig, *Prototractatus* (London: Routledge & Kegan Paul, 1971).